

DURACELL®

Size: 675

Zinc Air Battery – 0% Mercury

Zn/O₂

	
Nominal Voltage	1.45 V
Rated Capacity	625 mAh at 620 ohm to 1.1 V @ 21°C and 50% RH
Typical Impedance (Fresh)	2.0 ohm @ 1kHz
Typical Weight	1.68 g (0.059 oz)
Volume	0.57 cm ³ (0.035 in ³)
Terminals	Flat
Operating Temperature Range	0°C to 50°C (32°F to 122°F)
Recommended Storage Temperature	5°C to 30°C with 40-80% RH
Shelf Life	4 years unactivated @ 21°C
Designation	ANSI: 7003Z IEC: PR44

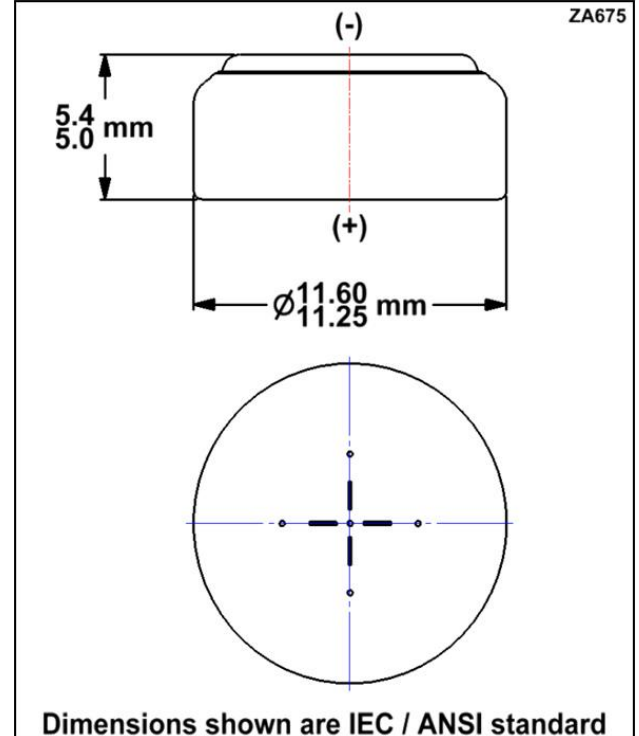

Typical Discharge Characteristics at 21°C (70°F) and 50% RH

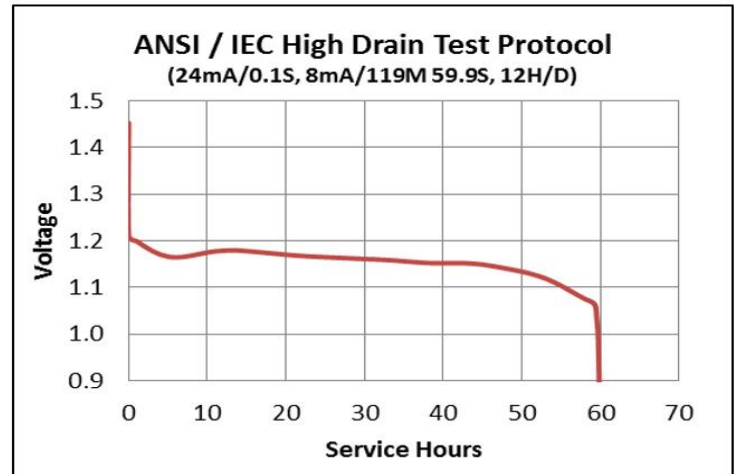
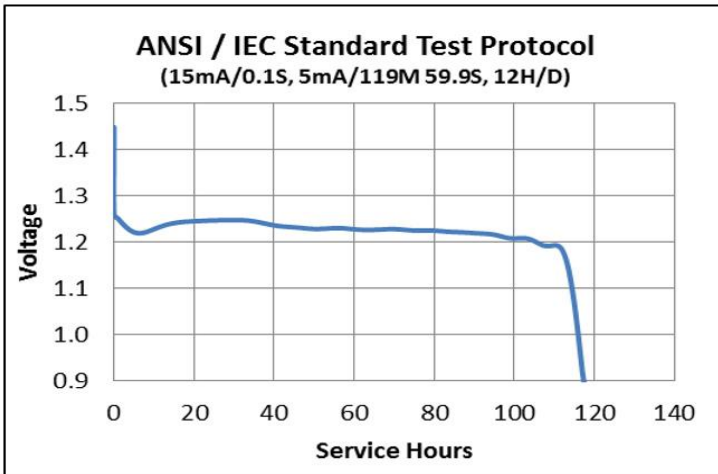

DURACELL®

BATTERIES

Berkshire Corporate Park
Bethel, CT. 06801 U.S.A.
Telephone: Toll-free 1-800-544-5454
www.duracell.com

Delivered capacity is dependent on the applied load, operating temperature and cut-off voltage. Please refer to the charts and discharge data shown for examples of the energy/service life that the battery will provide for various load conditions.